

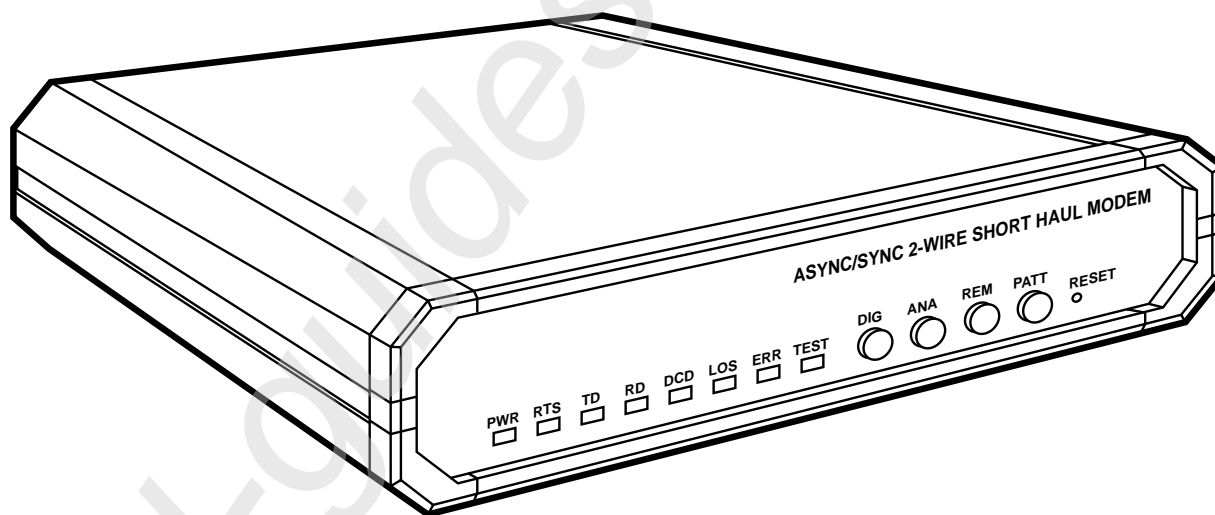

MARCH 1998
ME375A-R2
ME375AE-R2
ME376A-R2
ME376AE-R2

Async/Sync 2-Wire Short Haul Modem



CUSTOMER SUPPORT INFORMATION Order **toll-free** in the U.S. 24 hours, 7 A.M. Monday to midnight Friday: **877-877-BBOX**
FREE technical support, 24 hours a day, 7 days a week: Call **724-746-5500** or fax **724-746-0746**
Mail order: **Black Box Corporation**, 1000 Park Drive, Lawrence, PA 15055-1018
Web site: www.blackbox.com • E-mail: info@blackbox.com

FCC/IC RFI STATEMENTS, SAFETY WARNING

FEDERAL COMMUNICATIONS COMMISSION AND CANADIAN DEPARTMENT OF COMMUNICATIONS RADIO FREQUENCY INTERFERENCE STATEMENTS

This equipment generates, uses, and can radiate radio frequency energy and if not installed and used properly, that is, in strict accordance with the manufacturer's instructions, may cause interference to radio communication. It has been tested and found to comply with the limits for a Class A computing device in accordance with the specifications in Subpart J of Part 15 of FCC rules, which are designed to provide reasonable protection against such interference when the equipment is operated in a commercial environment. Operation of this equipment in a residential area is likely to cause interference, in which case the user at his own expense will be required to take whatever measures may be necessary to correct the interference.

Changes or modifications not expressly approved by the party responsible for compliance could void the user's authority to operate the equipment.

This digital apparatus does not exceed the Class A limits for radio noise emission from digital apparatus set out in the Radio Interference Regulation of the Canadian Department of Communications.

Le présent appareil numérique n'émet pas de bruits radioélectriques dépassant les limites applicables aux appareils numériques de classe A prescrites dans le Règlement sur le brouillage radioélectrique publié par le ministère des Communications du Canada.

SAFETY WARNING

Always observe standard safety precautions during installation, operation, and maintenance of this product. If you attempt to remove the power-supply fuse, be sure to disconnect the power cord from the power source first, in order to avoid the possibility of electric shock.

ASYNC/SYNC 2-WIRE SHORT-HAUL MODEMS

NORMAS OFICIALES MEXICANAS (NOM) ELECTRICAL SAFETY STATEMENT

INSTRUCCIONES DE SEGURIDAD

1. Todas las instrucciones de seguridad y operación deberán ser leídas antes de que el aparato eléctrico sea operado.
2. Las instrucciones de seguridad y operación deberán ser guardadas para referencia futura.
3. Todas las advertencias en el aparato eléctrico y en sus instrucciones de operación deben ser respetadas.
4. Todas las instrucciones de operación y uso deben ser seguidas.
5. El aparato eléctrico no deberá ser usado cerca del agua—por ejemplo, cerca de la tina de baño, lavabo, sótano mojado o cerca de una alberca, etc..
6. El aparato eléctrico debe ser usado únicamente con carritos o pedestales que sean recomendados por el fabricante.
7. El aparato eléctrico debe ser montado a la pared o al techo sólo como sea recomendado por el fabricante.
8. Servicio—El usuario no debe intentar dar servicio al equipo eléctrico más allá a lo descrito en las instrucciones de operación. Todo otro servicio deberá ser referido a personal de servicio calificado.
9. El aparato eléctrico debe ser situado de tal manera que su posición no interfiera su uso. La colocación del aparato eléctrico sobre una cama, sofá, alfombra o superficie similar puede bloquea la ventilación, no se debe colocar en libreros o gabinetes que impidan el flujo de aire por los orificios de ventilación.

NOM STATEMENT

10. El equipo eléctrico debe ser situado fuera del alcance de fuentes de calor como radiadores, registros de calor, estufas u otros aparatos (incluyendo amplificadores) que producen calor.
11. El aparato eléctrico deberá ser conectado a una fuente de poder sólo del tipo descrito en el instructivo de operación, o como se indique en el aparato.
12. Precaución debe ser tomada de tal manera que la tierra física y la polarización del equipo no sea eliminada.
13. Los cables de la fuente de poder deben ser guiados de tal manera que no sean pisados ni pellizcados por objetos colocados sobre o contra ellos, poniendo particular atención a los contactos y receptáculos donde salen del aparato.
14. El equipo eléctrico debe ser limpiado únicamente de acuerdo a las recomendaciones del fabricante.
15. En caso de existir, una antena externa deberá ser localizada lejos de las líneas de energía.
16. El cable de corriente deberá ser desconectado del cuando el equipo no sea usado por un largo periodo de tiempo.
17. Cuidado debe ser tomado de tal manera que objetos líquidos no sean derramados sobre la cubierta u orificios de ventilación.
18. Servicio por personal calificado deberá ser provisto cuando:
 - A: El cable de poder o el contacto ha sido dañado; u
 - B: Objetos han caído o líquido ha sido derramado dentro del aparato; o
 - C: El aparato ha sido expuesto a la lluvia; o
 - D: El aparato parece no operar normalmente o muestra un cambio en su desempeño; o
 - E: El aparato ha sido tirado o su cubierta ha sido dañada.

ASync/Sync 2-Wire Short-Haul Modems

Contents

Chapter	Page
1. Specifications	7
2. Introduction	10
3. Installation	11
3.1 Placement	11
3.2 Setting the Internal Controls	11
3.3 Connecting the Data Cables	16
3.4 Connecting to AC Power	17
4. Operation	19
4.1 The Front-Panel Controls and Indicators	19
4.2 Power-Up, Normal Operation, and Power-Down	22
4.3 Reconfiguration	23
5. Troubleshooting	24
5.1 Diagnostic Testing	24
5.2 Calling Black Box	28
5.3 Shipping and Packaging	28
Appendix: Pinouts	29
Legal Information	33

1. Specifications

Compliance —	FCC Part 15 Subpart J Class A, DOC Class/MDC classe A
Standard —	T1: ANSI T1.601.1988
Interfaces —	ME375 models: 2-wire telco, EIA RS-232; ME376 models: 2-wire telco, ITU-TSS (CCITT) V.35
Protocols —	DTE side: Synchronous or asynchronous; Line side: 2B1Q encoding
Clock Source —	Internal, external (from DTE), or received (from other unit), user-selectable
Data Format —	7 or 8 data bits; 1 or 2 stop bits; even, odd, or no parity (user-selectable)
Operation —	Line side: Full duplex with echo cancellation
Data Rate —	128, 115.2, 64, 57.6, 48, 38.4, 19.2, 9.6, 4.8, 2.4, 1.2, and 0.6 Kbps
Transmission Level —	Up to 14 dBm
Maximum Distance —	DTE side: ME375 models: 50 ft. (15.2 m); ME376 models: 25 ft. (7.6 m); Line side: 3.4 mi. (5.5 km) over 26-AWG wire, independent of data rate

ASync/Sync 2-Wire Short-Haul Modems

- User Controls** — (5) Front-mounted:
 (4) Pushbuttons: DIG (local digital loopback), ANA (local analog loopback), REM (remote digital loopback), and PATT (test pattern);
 (1) Recessed RESET switch;
 (6) Internal:
 (1) 7-position DIP switch for protocol, data format, and signaling options;
 (1) Rotary switch for data rate;
 (4) Jumpers for clock source, loopback testing, and ground connection
- Diagnostics** — V.54-compliant loopback tests:
 Local analog loopback (switch- or signal-triggerable);
 Local digital loopback (switch-triggerable);
 Remote digital loopback (switch- or signal-triggerable)
- Indicators** — (8) Front-mounted LEDs: PWR (power), RTS, TD, RD, DCD, LOS (loss of signal), ERR (error), and TEST
- Connectors** — ME375 models: (1) RJ-45 female, (1) 3-clip terminal block, and (1) DB25 female;
 ME376 models: (1) RJ-45 female, (1) 3-clip terminal block, and (1) 34-pin M-block female
- Leads/Signals Supported** — See the **Appendix**
- Power** — From internal power supply through included or alternate 5-ft. (1.5-m) power cord:
 ME375A-R2, ME376A-R2:
 Input: 103.5 to 131.5 VAC, 47 to 63 Hz;
 ME375AE-R2, ME376AE-R2:
 Input: 207 to 253 VAC, 47 to 63 Hz;
 Consumption: 5 VA

CHAPTER 1: Specifications

Fuse —	ME375A-R2, ME376A-R2: 0.1-A slow-blow; ME375AE-R2, ME376AE-R2: 0.2-A slow-blow
Other Power Protection —	AC/DC overvoltage-protection circuits connected through transformers to transmit and receive leads on the line side, plus special gas diodes
MTBF —	75,500 hours
Maximum Altitude —	8000 ft. (2438.4 m)
Temperature Tolerance —	32 to 122° F (0 to 50° C)
Humidity Tolerance —	Up to 90% noncondensing
Enclosure —	High-impact plastic
Size —	1.8"H x 7.6"W x 9.6"D (4.6 x 19.3 x 24.3 cm), but the unit's pushbuttons protrude up to 0.1" (25 mm) from the front panel and the connectors protrude up to 0.8" (1.9 cm) from the rear panel
Weight —	Net: 3.1 lb. (1.4 kg); Shipping: 6 lb. (2.7 kg)

ASYNC/SYNC 2-WIRE SHORT-HAUL MODEMS

2. Introduction

The Async/Sync 2-Wire Short Haul Modem (A/S2W SHM) operates synchronously or asynchronously at high speeds (600 bps to 128 Kbps) and in full duplex over one pair of dedicated telephone lines. It has a range of 3.4 miles (5.5 km) over 26-AWG wire.

The A/S2W SHM operates in full duplex over 2 wires by using the adaptive “echo-canceling” technique. Because it also uses 2B1Q line coding, it can achieve the range mentioned above no matter what the data rate is.

The A/S2W SHM incorporates interface circuits for the terminal/computer, an adaptive echo-canceler, an automatic adaptive equalizer, a modulator, and a demodulator. It is coupled to the telephone line through an isolation transformer, which protects against AC or DC overvoltages. The protection circuitry would enable the unit to operate even if DC were accidentally connected to the line.

The A/S2W SHM has diagnostic capabilities: It can perform local analog loopback and local and remote digital loopback. The operator at either end of the line may test both modems and the line in the remote digital loopback mode. Loopback can be controlled with either the unit’s front-panel pushbuttons or signals passed through the DTE (PC, data-terminal) interface.

3. Installation

This chapter tells you how to configure and install the Async/Sync 2-Wire Short Haul Modem. After you finish doing this, refer to **Chapter 4** for operating information.

3.1 Placement

The Async/Sync 2-Wire Short Haul Modem is designed to be placed on a tabletop, shelf, or bench, and is delivered completely assembled. (No provisions are made for bolting the A/S2W SHM to any surface.)

The A/S2W SHM should be installed within 1.5 m (5 ft) of a grounded AC outlet and must be situated within 25 ft. (7.6 m—ME376 models) or 50 ft. (15 m—ME375 models) of the associated data terminal.

Allow at least 36" (90 cm) of clearance in front of the unit so you can access it during operation and maintenance. Make sure that there is at least 4" (10 cm) of clearance behind the unit for signal lines and interface cables.

3.2 Setting the Internal Controls

Before you install any cabling and definitely before you plug in the unit, you should set the Async/Sync 2-Wire Short Haul Modem's internal controls to suit your application. (If you don't feel comfortable about doing this yourself, get an experienced technician to do it or to help you.) To access the internal controls, first make sure the A/S2W SHM is disconnected from AC power, then unscrew the two screws on the unit's rear panel and slide the bottom half of the unit out from beneath its cover.

Refer to Figure 3-1 on the next page and Table 3-1 on the succeeding pages for the locations of the controls and their possible settings respectively.

ASYNC/SYNC 2-WIRE SHORT-HAUL MODEMS

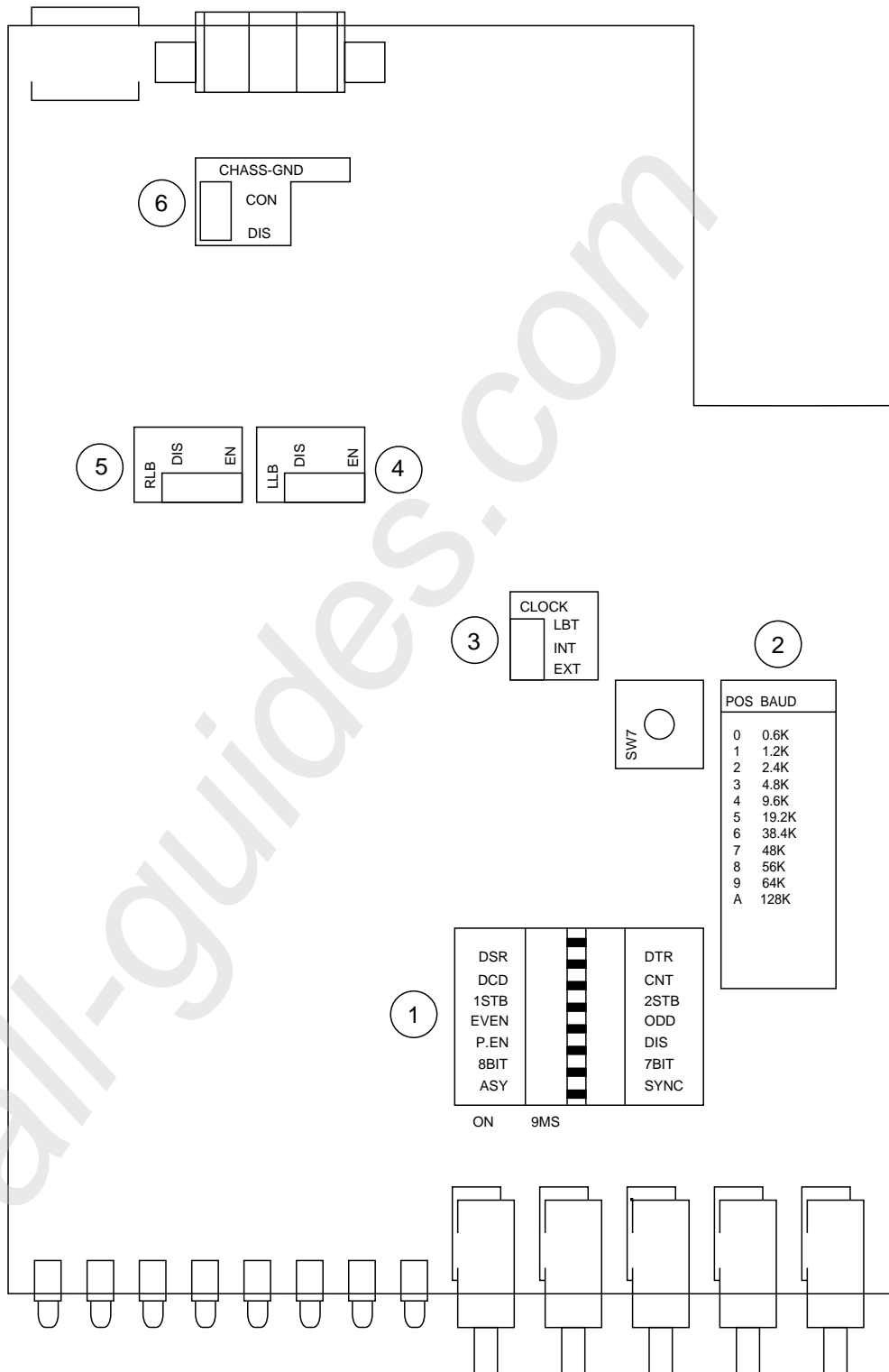

Figure 3-1. The A/S2W SHM's internal controls and indicators.

CHAPTER 3: Installation**Table 3-1. Possible Settings of Internal Controls**

Callout No. in Fig. 3-1	Description	Position/Label	Possible Settings	Factory-Default Setting
1	DIP Switch	Position 1 ON = ASYNC OFF = SYNC Position 2 ON = 8BIT OFF = 7BIT Position 3 ON = PRTY OFF = DIS Position 4 ON = EVEN OFF = ODD Position 5 ON = 1STB OFF = 2STB Position 6* ON = DCD OFF = CNT Position 7† ON = DSR OFF = DTR	Async or sync operation 8 or 7 data bits Parity enabled or disabled Even or odd parity 1 or 2 stop bits DCD independent or controlled by RTS DSR always ON or follows DTR	Sync 8 bits Disabled Even 1 bit DCD ind. DSR ON

*If DIP Switch Position 6 is set to:

- DCD: The DCD signal is ON as long as the local unit is in proper synchronization with the remote unit. The DCD signal is OFF when digital loopback is active or when there is no synchronization (for example, while the unit is receiving the remote loopback command).
- CNT: The local unit's DCD signal follows the remote unit's RTS signal.

†If DIP Switch Position 7 is set to:

- DSR: The DSR signal is ON as long as the local unit is receiving AC power; it does not indicate the existence of a communication channel or the status of the remote site.
- DTR: The local unit's DSR signal follows the remote unit's DTR signal.

ASYNCR/SYNCR 2-WIRE SHORT-HAUL MODEMS

Table 3-1. Possible Settings of Internal Controls (cont'd.)

Callout No. in Fig. 3-1	Description	Position/Label	Possible Settings	Factory-Default Setting
2	Data-Rate Dial*	Position 0 0.6K Position 1 1.2K Position 2 2.4K Position 3 4.8K Position 4 9.6K Position 5 19.2K Position 6 38.4K Position 7 48K (Position 8 56K)† Position 9 64K Position A 128K (Position B 144K)† Position C 57.6K** Position C 115.2K**	0.6 Kbps 1.2 Kbps 2.4 Kbps 4.8 Kbps 9.6 Kbps 19.2 Kbps 38.4 Kbps 48 Kbps (56 Kbps) 64 Kbps 128Kbps (144 Kbps) 57.6 Kbps 115.2 Kbps	64 Kbps (P9)

*Setting this dial has no effect or purpose if the unit is set to use the external clock.

†These data-rate settings are not supported by the standard A/S2W SHM. If you need to transfer data at one of these speeds, call Black Box Technical Support for a special quote on a unit that will.

**These settings (popular speeds for direct computer-to-computer communication) do not work properly unless the A/S2W SHM communicates with the DTE asynchronously (DIP Switch Position 1 set to ON).

CHAPTER 3: Installation**Table 3-1. Possible Settings of Internal Controls (cont'd.)**

Callout No. in Fig. 3-1	Description	Function/Label	Possible Settings	Factory-Default Setting
3	Clock-Source (CLOCK) Jumper	For master units, select either internal timing (INT) or external timing (EXT). For slave units, always select loopback (received) timing (LBT).	INT EXT LBT	INT
4	Local Loopback (LLB) Jumper*	Enable/disable control of local analog loopback testing with signals from the DTE	DIS EN	DIS
5	Remote Loopback (RLB) Jumper*	Enable/disable control of remote digital loopback testing with signals from the DTE	DIS EN	DIS
6	Chassis-Ground (CHASS_GND) Jumper	Tie Signal Ground to Chassis (Protective, Frame) Ground or isolate the two grounds from each other	CON DIS	CON

*Only connect the RLB and LLB jumpers (that is, set them to EN [enabled]) if you want to be able to turn local analog or remote digital loopbacks on and off from the DTE using the proper RS-232 or V.35 signals. The settings of these jumpers have no effect on the ANA and REM pushbutton switches on the unit's front panel; you will be able to control loopback testing with those buttons whether these jumpers are connected or not. (There is no way to control local digital loopback through the local DTE interface; you must use the DIG button to do that.)

ASYNC/SYNC 2-WIRE SHORT-HAUL MODEMS

3.3 Connecting the Data Cables

To connect your data cables to the Async/Sync 2-Wire Short Haul Modem, take these steps, referring to Figure 3-2 below:

1. Connect the twisted-pair transmission line to the two clips marked LINE (or Pins 4 and 5 of the RJ-45 connector) and (optionally) the cable shield to the clip marked GND (or Pin 2 of the RJ-45 connector). If you are using the connecting the line to the clips, refer to Wire-Insertion Details on the next page. We highly recommend that for your transmission line you use twisted-pair cable capable of supporting high data rates, especially Category 3 or better, in order to prevent crosstalk. Our product code for a type of cable that fits the bill, bulk unterminated Category 5 UTP, is EYN717A (specify the length you want).
2. Run the DTE-side cable from the DTE to the A/S2W SHM. If your A/S2W SHM is an ME375 model, this cable should be straight-through-pinned and 50 or fewer feet (15.2 or fewer meters) long; it should also have a DB25 female connector on the DTE end and a DB25 male connector on the A/S2W SHM end. (Our product code for this type of cable is ECM25C; specify the length you want and “male-female” genders).

If your A/S2W SHM is an ME376 model, this cable should be straight-through-pinned and 25 or fewer feet (7.6 or fewer meters) long; it should also have a 34-pin M-block male connector on the A/S2W SHM end. (Our product code for this type of cable is EYN450; specify the length and genders you want.)

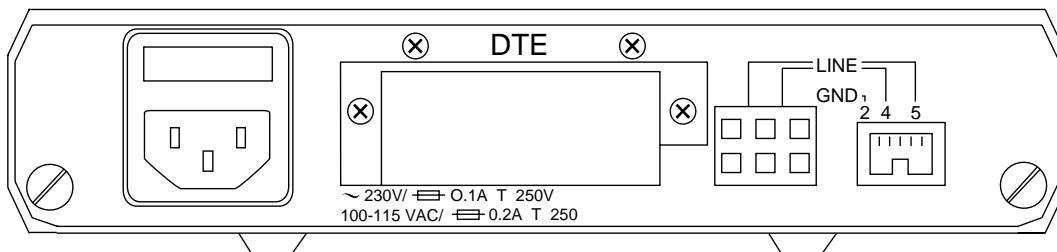
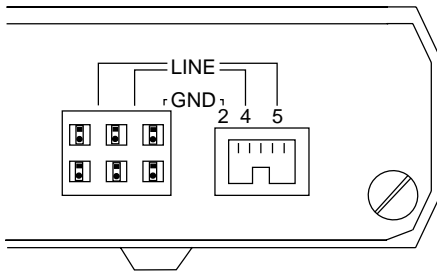

Fig. 3-2. The A/S2W SHM's rear panel.

CHAPTER 3: Installation



Wire Insertion Details

- 1) Insert screwdriver into square hole.

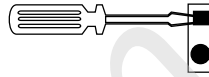

- 2) Raise inserted screwdriver, putting pressure on the ramp within the square hole. The wire clamp within the round hole will open.

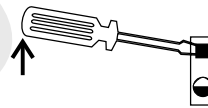

- 3) Insert the stripped end of the wire and remove the screwdriver.

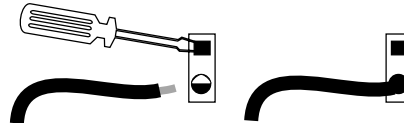

3.4 Connecting to AC Power

AC power is supplied to the A/S2W SHM through an included or alternate 1.5-m (5 ft) cord terminated with a grounded plug. Make sure that, before you plug the cord into the unit and an outlet, that proper grounding rules are observed:

- If you are using an alternate cord, it must have a ground wire that runs from the unit's ground (earth) terminal (the topmost of the three prongs on the unit's IEC 320 male power inlet) to the ground terminal on the outlet.
- Do not use an extension cord with the unit unless it also has a ground wire that runs between ground terminals at either end.

Once you are sure of proper grounding, run the power cord from the A/S2W SHM's IEC320 male power inlet to a working outlet. As soon as the cord is plugged in at both ends, the unit will begin operating, because it has no power switch. (To turn the unit on and off, you must plug it in and unplug it.) The PWR LED should light; see **Section 4.2**.

ASync/Sync 2-Wire Short-Haul Modems

While the A/S2W SHM is ON, operating personnel are not exposed to more than 30 volts on any card or on any accessible area of the DC power supply. Nevertheless, never open the unit or try to maintain or reconfigure it while it is plugged in.

The AC cord is fused at the rear panel of the unit. If this fuse blows, make sure you replace it only with a fuse rated for the required current and of the specified type (0.2-A slow-blow for ME375A-R2 and ME376A-R2, 0.1-A slow-blow for ME375AE-R2 and ME376AE-R2). An extra fuse should have been included with the unit. Until you replace a blown, damaged, or missing fuse, unplug the unit and make sure that no one attempts to use it. Avoid using repaired fuses, and never “get by” without the fuse by short-circuiting the fuse holders!

4. Operation

This chapter lists the Async/Sync 2-Wire Short Haul Modem's external controls and indicators, describes their functions, and describes operating procedures. Complete and confirm the installation procedures described in **Chapter 3** before you attempt to operate the A/S2W SHM. If you have difficulty, refer to **Chapter 5**.

4.1 The Front-Panel Controls and Indicators

Figure 4-1 below shows the front panel of the Async/Sync 2-Wire Short Haul Modem, including all of the controls and LED indicators mounted on it. These controls and indicators are described in Tables 4-1 and 4-2 on the next two pages.

Fig. 4-1. The A/S2W SHM's front panel.

ASYNC/SYNC 2-WIRE SHORT-HAUL MODEMS

Table 4-1. Front-Panel Controls and Their Functions

Control	Function
DIG	Press this Local Digital Loopback button to cause the local A/S2W SHM to loop received data and clock signals from the line back out of its own transmitter. This is equivalent to activating remote digital loopback (see below) on the remote unit. Press this button again to terminate local digital loopback.
ANA*	Press this Local Analog Loopback button to cause the local A/S2W SHM to loop its transmitter output back into its own receiver. Press this button again to terminate local analog loopback. While the A/S2W SHM's LLB jumper is set to EN (enabled—see the third part of Table 3-1 on page 15), you can also control this type of loopback by raising and lowering the LL signal from the DTE on the appropriate pin for your interface.
REM*	Press this Remote Digital Loopback button to cause the remote A/S2W SHM to loop received data and clock signals back out of its own transmitter. (Data Set Ready goes low when this happens.) Press this button again to terminate remote digital loopback. While the A/S2W SHM's RLB jumper is set to EN (enabled—see the third part of Table 3-1 on page 15), you can also control this type of loopback by raising and lowering the RL signal from the DTE on the appropriate pin for your interface.
PATT	Press this Pattern button to cause the local A/S2W SHM to send the remote unit a continuous Bit Error Rate test pattern. Press this button again to stop sending the test pattern.
RESET	Carefully press a long thin object such as a tack or the end of a paper clip into this recessed switch to reset the A/S2W SHM. Do this to clear abnormal conditions (the indication of an error condition, for example) instead of unplugging the unit and plugging it back in.

*The ANA and REM buttons are not affected by the settings of the RLB and LLB jumpers (see the third part of Table 3-1 on page 15). Even if those jumpers are set to DIS (disabled), you can still control loopback testing with these buttons.

Table 4-2. Front-Panel Indicators and Their Functions

Indicator	ITU-TSS (CCITT) Circuit	Function
PWR		Green LED is steadily lit while power is present.
RTS	105	Yellow LED is steadily lit while the Request to Send (RTS) signal from the DTE is high.
TD	103	Yellow LED is steadily lit while the local A/S2W SHM transmits steady SPACE. It flickers while the local unit transmits data.
RD	104	Yellow LED is steadily lit while the local A/S2W SHM receives steady SPACE. It flickers while the local unit receives data.
DCD	109	Yellow LED is steadily lit while: <ul style="list-style-type: none"> a) The local and remote A/S2W SHMs are in sync, and the local unit's DCD switch is set to "DCD"; b) The local and remote A/S2W SHMs are in sync, the local unit's DCD switch is set to "CNT", and the remote unit has RTS high.
LOS		Red LED is steadily lit when synchronization between the local and remote A/S2W SHMs is lost.
ERR		Red LED is steadily lit when the local A/S2W SHM's PATT button is in the ON position (depressed) and the unit detects an error in the BERT pattern.
TEST		Yellow LED is steadily lit while the local A/S2W SHM's internal BERT is active (the PATT button is depressed) or the unit is in any of the three loopback modes.

ASYNC/SYNC 2-WIRE SHORT-HAUL MODEMS

4.2 Power-Up, Normal Operation, and Power-Down

Making sure that you follow the guidelines in **Section 3.4**, power up the Async/Sync 2-Wire Short Haul Modem by plugging its AC power cord to an working AC outlet. (The unit has no power switch. To power it down, unplug it.) The PWR LED should light, indicating that the unit is on.

If the local and remote A/S2W SHM units are both operating and transmitting data, the units' front-panel indicators should look like this:

- PWR** Steadily lit
- TD** Steadily lit or flickering depending on the data being transmitted.
- RD** Steadily lit or flickering depending on the data being received.
- RTS** Steadily lit or dark depending on the status of the RTS signal from the local DTE.
- DCD** If the local unit's DCD jumper is set to DCD, steadily lit; if the local unit's DCD jumper is set to CNT, steadily lit or dark depending on the status of the RTS signal from the remote unit.
- LOS** Flashing until the units synchronize with each other, then dark.
- ERR** Flashing until the units synchronize with each other, then dark.
- TEST** Flashing until the units synchronize with each other, then dark.

If the LEDs don't look like this, make sure that:

- One A/S2W SHM's CLOCK jumper is set to internal (INT) or external (EXT) clock, and the other unit's CLOCK jumper is set to loopback (LBT) clock.
- Both units' four front-panel pushbuttons are in the OFF position (not depressed).

Once a A/S2W SHM begins operating normally, it will continue to do so indefinitely without needing to be attended, except when occasional monitoring of LED indicators is required. If you have difficulty, perform the diagnostic tests described in **Section 5.1**. If you still can't solve the problem, call Black Box as described in **Section 5.2**.

4.3 Reconfiguration

If it becomes necessary to reconfigure your A/S2W SHMs for a different type of operation, you will have to reposition the units' internal controls. (If you don't feel comfortable about doing this yourself, get an experienced technician to do it or to help you.) Take these steps:

1. Unplug the local unit and temporarily detach the data cables from it.
3. Open the unit's cover.
4. Referring to Figure 3-1 on page 12 and Table 3-1 on pages 13 through 15, set the unit's internal controls to suit the new application.
5. Close the cover.
6. Perform Steps 1 through 5 at the remote site.
7. Reattach the data cables to both units and plug both units back in.

The A/S2W SHMs should begin operating with their new parameters. If there are problems, make sure that both units are set correctly. If they are, perform the diagnostic tests described in **Section 5.1**. If you still can't solve the problem, call Black Box as described in **Section 5.2**.

ASYNC/SYNC 2-WIRE SHORT-HAUL MODEMS

5. Troubleshooting

5.1 Diagnostic Testing

If you have problems with data communication on your Async/Sync 2-Wire Short Haul Modem system, or if you just want to verify proper system operation, the A/S2W SHM has diagnostic capabilities that can help you. You can use the A/S2W SHM's front-panel pushbuttons to control different kinds of tests with which you can quickly check the A/S2W SHM, the attached cables (including the transmission line), and the local DTE. By performing these tests, you can quickly find out which components of your A/S2W SHM system are operating properly and which aren't.

Before you begin testing, make sure that both of the A/S2W SHMs and both DTEs are powered up and configured normally. When you have verified this, perform the tests described in **Sections 5.1.1, 5.1.2, and 5.1.3**, in that order.

5.1.1 LOCAL ANALOG LOOPBACK

Use this test to check the performance of the local modem, the local DTE, and the cables between them. Perform this test separately at both the local and remote sites (refer to Figure 5-1 on the next page). Take these steps:

1. Push the local A/S2W SHM's ANA (Local Analog Loopback) button or (if the unit's LLB jumper is set to EN) raise the LL signal from the DTE to the unit. The unit should light its TEST LED as it internally connects its transmitter output to its own receiver circuits.
2. Verify that the DTE is operating properly and can be used for a test. If the DTE is malfunctioning, replace it or have it repaired.
3. Observe what happens to test data that you send and get back: Set the DTE to half duplex and get an "echo" through the system and/or use special Bit Error Rate Test (BERT) equipment.

CHAPTER 5: Troubleshooting

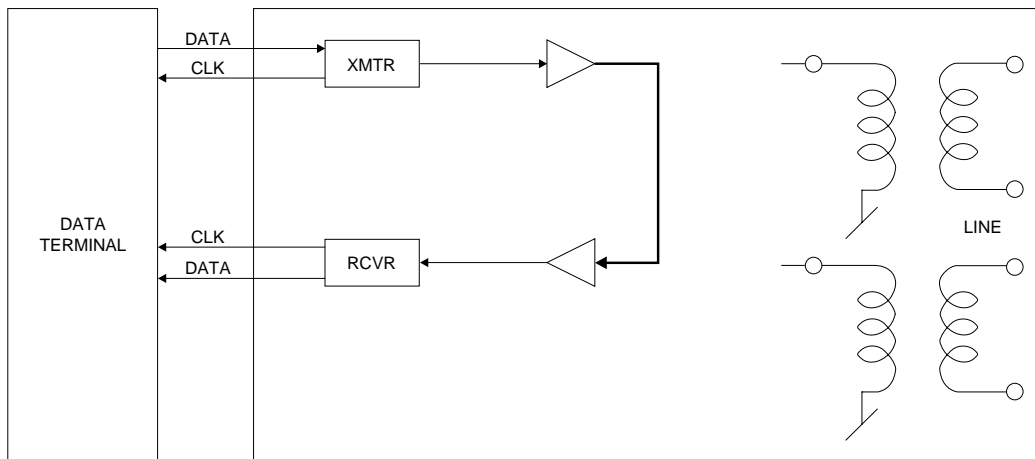

Fig. 5-1. Local analog loopback.

4. If you use a BERT unit and it indicates an error, make sure the cables connecting it to the A/S2W SHM are securely connected. If they are, try swapping in known-good cables. If the error goes away, the problem was probably in the old cables. Otherwise, the A/S2W SHM is probably faulty; call Black Box for technical support.

If you use a BERT unit and it indicates all clear, but you get errors when you perform the DTE test, the DTE is probably the source of the problem. Make sure that it is physically intact and that it is configured correctly. Refer to your DTE's manual if necessary, and if you can't solve the problem, call your DTE's supplier.

If you don't have a BERT unit, and the DTE test indicates an error, make sure the cables connecting the DTE to the A/S2W SHM are securely connected. If they are, try swapping in known-good cables. If the error goes away, the problem was probably in the old cables. Otherwise, the DTE is probably the source of the problem. Make sure that it is physically intact and that it is configured correctly. Refer to your DTE's manual if necessary, and if you can't solve the problem, call your DTE's supplier.

5. After completing the test (or when the fault has been corrected), return the ANA button to the OFF position by pushing it again or, if you're controlling the test electronically, lower the LL signal from the DTE to the unit.
6. Repeat Steps 1 through 5 at the remote site.

Proceed with the Remote Digital Loopback test.

ASYNC/SYNC 2-WIRE SHORT-HAUL MODEMS

5.1.2 REMOTE DIGITAL LOOPBACK

Use this test to determine how the line-side circuits of the local and remote A/S2W SHMs and the 2-wire line between them are performing:

1. Push the local unit's REM (Remote Digital Loopback) pushbutton or (if the unit's RLB jumper is set to EN) raise the RL signal from the DTE to the unit. The TEST LED should light on both units as the local unit sends a remote-loopback command to the remote unit and the remote unit internally connects its receiver input to its transmitter output (see Figure 5-2 below).
2. Perform a DTE test and/or BERT as described in Step 3 of the Local Analog Loopback procedure. You can also press the local unit's PATT button to have it send a test pattern through the loop. (Press the PATT button again to stop the test pattern.)
3. If Step 2 indicates a fault, but Local Analog Loopback testing was successful for both A/S2W SHMs, either the line connection between the units is faulty, or the 2-wire line circuits inside one or both of the units are not operating properly. If possible, try a different line. If this is impossible, or if the problem does not go away when you use a different line, call Black Box for technical support.
4. After completing the test (or when the fault has been corrected), return the REM button to the OFF position by pushing it again or, if you're controlling the test electronically, lower the RL signal from the DTE to the unit.

Proceed with the Local Digital Loopback test.

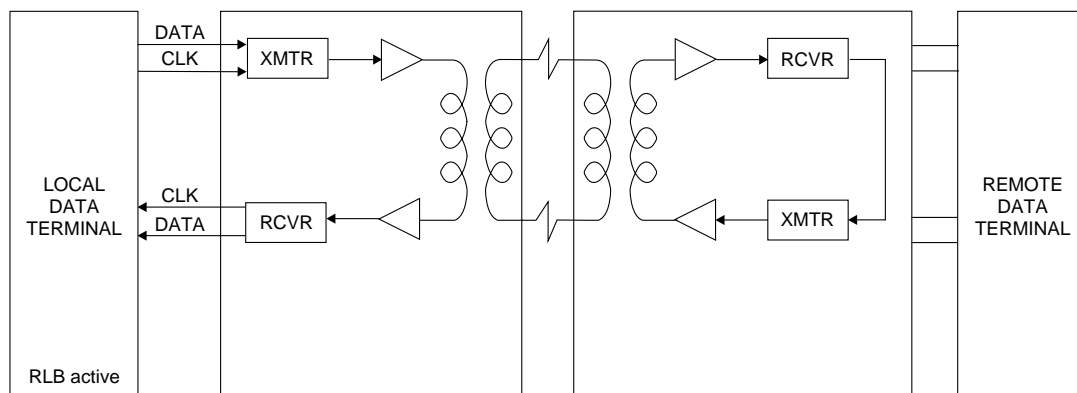

Fig. 5-2. Remote digital loopback.

CHAPTER 5: Troubleshooting

5.1.3 LOCAL DIGITAL LOOPBACK

This test is essentially the same as the Remote Digital Loopback test, but performed “in reverse,” so to speak. It allows you to make doubly sure of the line and the A/S2W SHMs’ line-side circuitry by setting up a loop in the opposite direction. Take these steps:

1. Push the local unit’s DIG (Local Digital Loopback) pushbutton. (There is no way to initiate this test electronically.) The TEST LED should light on both units as the local unit sends a local-loopback notification to the remote unit and then internally connects its receiver input to its transmitter output (see Figure 5-3 below).
2. The operator at the remote site can test the units and the lines and take remedial action as described in Steps 2 and 3 of the Remote Digital Loopback procedure.
3. When the operator at the remote site notifies you that he or she has finished, return the DIG button to the OFF position by pushing it again.

If you have been unable to solve the problem, call Black Box for technical support as described in the next section.

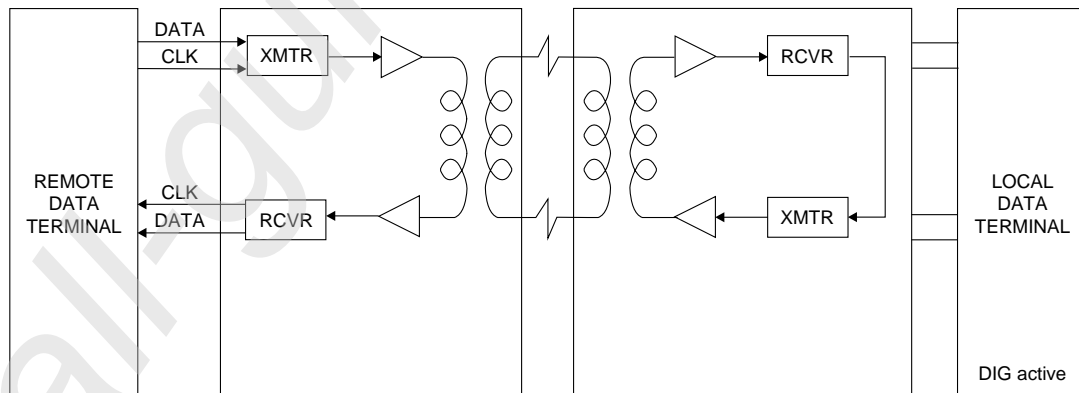

Fig. 5-3. Local digital loopback.

ASYNC/SYNC 2-WIRE SHORT-HAUL MODEMS

5.2 Calling Black Box

If you determine that your Async/Sync 2-Wire Short Haul Modem is malfunctioning, *do not attempt to alter or repair it*. It contains no user-serviceable parts. Contact Black Box Technical Support at 724-746-5500; the problem might be solvable over the phone.

Before you do, make a record of the history of the problem. We will be able to provide more efficient and accurate assistance if you have a complete description, including:

- The nature and duration of the problem.
- When the problem occurs.
- The components involved in the problem.
- Any particular application that, when used, appears to create the problem or make it worse.
- The results of any testing you've already done.

5.3 Shipping and Packaging

If you need to transport or ship your Async/Sync 2-Wire Short Haul Modem:

- Package it carefully. We recommend that you use the original container.
- Before you ship a unit for repair or return, contact Black Box to get a Return Materials Authorization (RMA) number, and make sure you include everything you received with the unit when you ship it.

Appendix: Pinouts

The table below and on the following pages describes the leads and signals supported by the two models of the Async/Sync 2-Wire Short Haul Modem.

ITU-TSS (CCITT) V.24 Circuit	EIA RS-232 Pin (ME375)	Signal Name/ Abbreviation for EIA RS-232 (ME375)	ITU-TSS V.35 Pin(s) (ME376)	Signal Name/ Abbreviation for ITU-TSS V.35 (ME376)	Description
101	1	Protective Ground (PGND)	A	Frame Ground (FGND)	Chassis ground. May be connected to or isolated from Signal Ground by setting the GROUND jumper.
102	7	Signal Ground (SGND)	B	Signal Ground (SGND)	Signal ground. May be connected to or isolated from Protective/Frame Ground by setting the GROUND jumper.
103	2	Transmit Data (TD)	P S	Send Data A (SD A) Send Data B (SD B)	Serial digital data received from the DTE. In synchronous applications, the data transitions must occur on the rising edge of the transmit clock.
104	3	Receive Data (RD)	R T	Receive Data A (RD A) Receive Data B (RD B)	Serial digital data sent to the DTE. In synchronous applications, the data transitions occur on the rising edge of the clock.
105	4	Request to Send (RTS)	C	Request to Send (RTS)	The DTE raises this signal to the A/S2W SHM when it wants to transmit data.
106	5	Clear to Send (CTS)	D	Clear to Send (CTS)	The A/S2W SHM raises this signal to the DTE when it is ready to receive.

ASYNC/SYNC 2-WIRE SHORT-HAUL MODEMS

ITU-TSS (CCITT) V.24 Circuit	EIA RS-232 Pin (ME375)	Signal Name/ Abbreviation for EIA RS-232 (ME375)	ITU-TSS V.35 Pin(s) (ME376)	Signal Name/ Abbreviation for ITU-TSS V.35 (ME376)	Description
107	6	Data Set Ready (DSR)	E	Data Set Ready (DSR)	If DIP Switch Position 7 is set to DSR, the A/S2W SHM holds this signal high unless it is in digital loopback or receives a remote-loopback signal from the remote unit. If DIP Switch Position 7 is set to DTR, the A/S2W SHM lets this signal follow (reflect) the remote unit's DTR.
108.2	20	Data Terminal Ready (DTR)	H	Data Terminal Ready (DTR)	The DTE raises this signal when it is ready to transmit or receive. If the remote unit's DIP Switch Position 7 is set to DTR, the remote unit's DSR will follow (reflect) this signal.
109	8	Received Line Signal Detector (RLSD)	F	Received Line Signal Detector (RLSD)	More commonly known as Data Carrier Detect (DCD). The A/S2W SHM holds this signal high unless RTS goes low or carrier is lost.
113	24	Transmitter Signal Element Timing [DTE] (TSETT)	U W	Serial Clock Transmit External A (SCTE A) Serial Clock Transmit External B (SCTE B)	More commonly known as External Clock (EXC). The DTE sends this data-rate clock signal to the A/S2W SHM, which in turn passes it to the remote unit. The A/S2W SHM derives its sync clock from this signal only if its CLOCK jumper is set to EXT. Positive clock transitions correspond to positive data transitions.

APPENDIX: Pinouts

ITU-TSS (CCITT) V.24 Circuit	EIA RS-232 Pin (ME375)	Signal Name/ Abbreviation for EIA RS-232 (ME375)	ITU-TSS V.35 Pin(s) (ME376)	Signal Name/ Abbreviation for ITU-TSS V.35 (ME376)	Description
114	15	Transmitter Signal Element Timing [DCE] (TSETC)	Y AA	Serial Clock Transmit A (SCT A) Serial Clock Transmit B (SCT B)	More commonly known as Transmit Clock (TXC). The A/S2W SHM sends this data-rate clock signal to the DTE and the remote unit. The A/S2W SHM derives its sync clock from this signal only if its CLOCK jumper is set to INT. Positive clock transitions correspond to positive data transitions.
115	17	Receiver Signal Element Timing [DCE] (RSETC)	V X	Serial Clock Receive A (SCR A) Serial Clock Receive B (SCR B)	More commonly known as Receive Clock (RXC). The remote A/S2W SHM sends this data-rate clock signal to the local unit, which in turn passes it to the DTE. The A/S2W SHM derives its sync clock from this signal only if its CLOCK jumper is set to LBT. Positive clock transitions correspond to positive data transitions.
140	21	Remote Loopback (RL)	HH	Remote Loopback (RL)	The DTE raises this signal to the A/S2W SHM to cause it to begin and maintain remote digital loopback (V.54 Loop 2). The A/S2W SHM ignores this signal unless its RLB jumper is set to EN.
141	18	Local Loopback (LL)	JJ	Local Loopback (LL)	The DTE raises this signal to the A/S2W SHM to cause it to begin and maintain local analog loopback (V.54 Loop 3). The A/S2W SHM ignores this signal unless its LLB jumper is set to EN.

ASYNC/SYNC 2-WIRE SHORT-HAUL MODEMS

ITU-TSS (CCITT) V.24 Circuit	EIA RS-232 Pin (ME375)	Signal Name/ Abbreviation for EIA RS-232 (ME375)	ITU-TSS V.35 Pin(s) (ME376)	Signal Name/ Abbreviation for ITU-TSS V.35 (ME376)	Description
142	25	Test Mode (TM)	KK	Test Mode (TM)	The A/S2W SHM raises this signal during any test and any time its internal BERT is activated (the PATT button is depressed).

LEGAL INFORMATION

DISCLAIMERS

No representation for fitness of this product for any purpose other than those specifically mentioned in this manual is made either by the manufacturer or its agents.

The manufacturer shall not be liable for any direct, indirect, special, incidental, or consequential damages, whether based on contract, tort, or any legal theory.

RESERVED RIGHTS

This document contains materials protected by copyright, including information belonging to the manufacturer. All rights are reserved. No part of this manual may be reproduced or transmitted in any form, by any means or for any purpose, without express written consent.

The manufacturer and its agents reserve the right to revise this publication or make changes without obligation to notify any person of such revisions or changes.

NOTES



©Copyright 1998. Black Box Corporation. All rights reserved.

1000 Park Drive • Lawrence, PA 15055-1018 • 724-746-5500 • Fax 724-746-0746