

TANNOY®

CMS60 TDC – 60 / CMS60 TDC - 8
User Manual

HOLE CUT- OUT SIZE
305mm (12")

CONTENTS

1. Introduction
2. Unpacking
 - 2.1 CMS60 TDC – 60 / CMS60 TDC - 8 – The Product
 - 2.2 The C-ring
 - 2.3 The Tile Bridge and C-ring
 - 2.4 The Plaster 'Mud' Ring
3. Installation Instructions
 - 3.1 Hole Cut Out
 - 3.2 Connections
 - 3.3 Installation
 - 3.4 Speaker Assembly with C-ring
 - 3.5 Speaker Assembly with Tile Bridge and C-ring
4. Polarity Checking
5. Amplification and Power Selection (Low Impedance Mode)
6. Voltage and Power Selection (Distributed Line Operation)
7. Equalisation
8. Dimensions
9. Performance Data
10. Technical Specifications
11. CMS60 TDC Recommended Service Parts & Accessories
12. Warranty
13. Declaration of Conformity

1. Introduction

The Tannoy CMS60 TDC – 60 / CMS60 TDC - 8 Ceiling Monitor System has been designed for high-level music and speech reinforcement applications requiring exceptional sonic quality with uncompromised reliability. The utmost consideration has been given to the installation procedure to ensure that this product is quick and easy to install.

The CMS60TDC is best described as a premium quality 'Ceiling Monitor System'; the heart of which is the 165mm (6.5") Tannoy proprietary Dual Concentric™ transducer. This drive unit, also used in Tannoy studio monitors, incorporates latest generation design features including a dual magnet assembly, HF Tulip WaveGuide™ and injection moulded polypropylene LF cone. The low frequency (LF) and high frequency (HF) sources are coincidentally aligned to a point source, resulting in a smooth uniform frequency response over a wide area of coverage, this is unachievable with discrete two-way designs in the vertical plane where massive cancellations appear off axis at the crossover frequency.

The Tannoy proprietary Dual Concentric™ transducer is housed in a rugged aluminium ceiling enclosure that has been optimally tuned to achieve maximum bass response and tonal balance. Also located in this enclosure is a Tannoy THP60 multi-tap transformer for distributed-line operation. The transformer provides high system sensitivity, a wide bandwidth and dynamic range, with very low insertion loss. The CMS60 TDC – 60 / CMS60 TDC - 8 can also be used in low impedance systems with this selection being made (along with the transformer tapping options) via a single rotary switch located on the front baffle for quick and simple commissioning.

*No Transformer with CMS60 TDC – 8, low impedance only.

2. Unpacking

Every Tannoy CMS60 TDC – 60 / CMS60 TDC - 8 product has been carefully tested and inspected before being packaged and leaving the factory to make sure it reaches you in perfect condition. However, we would ask you to make sure that no damage has occurred in transit. In the unlikely event of any damage, would you please notify your dealer immediately and retain the carton and packing materials. Your dealer may ask you to return the damaged unit for inspection.

The CMS60 TDC – 60 / CMS60 TDC - 8 is packed in pairs, and any additional optional extras will be provided in separate packaging. These options include: C Ring, Tile Bridge and Plaster Ring. The cardboard paint guard should be removed before use.

2.1 CMS60 TDC – 60 / CMS60 TDC - 8 – The Product

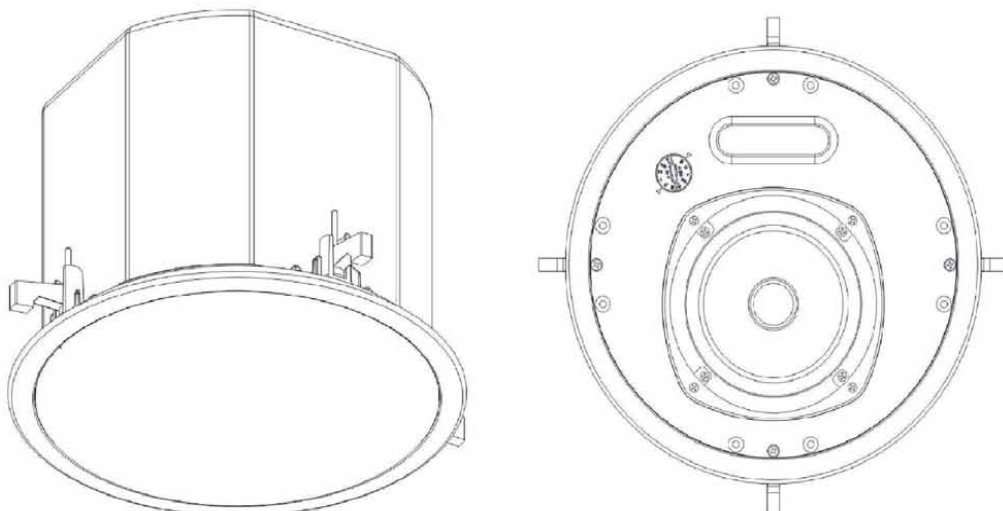

2.2 The C-ring (Optional)



2.3 The Tile Bridge and C-ring (Optional)

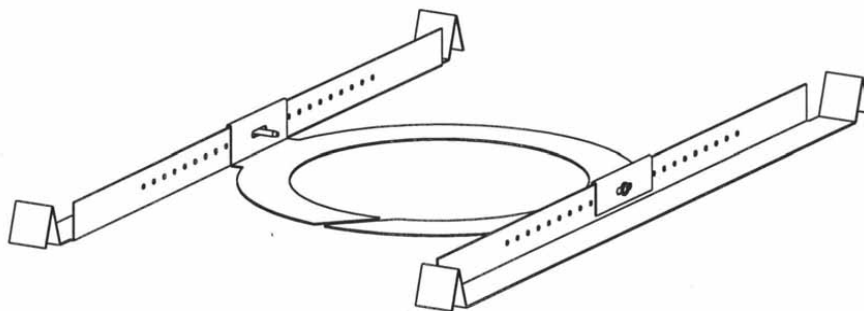

2.4 The Plaster 'Mud' Ring (Optional)

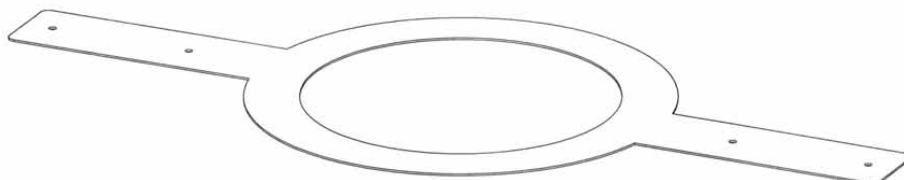

3. Installation Instructions

3.1 Hole Cut Out

The cutout size required is 305mm (12")

3.2 Connections

The CMS60 TDC – 60 / CMS60 TDC - 8 is provided with a plugable European type connector, which is located on the back of the speaker can, under the wiring cover as shown in **Figure 3a** below. This consists of a plug and socket. The plug can be removed from the socket (**Figure 3b**) for wiring.

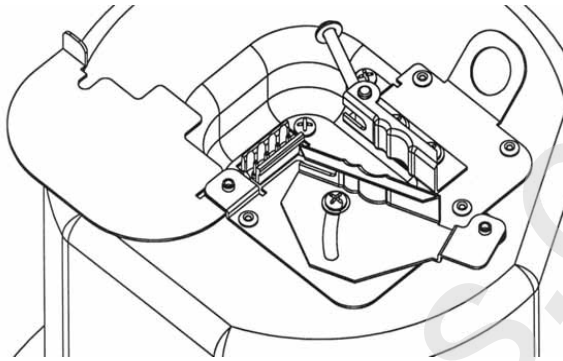

Figure 3a.

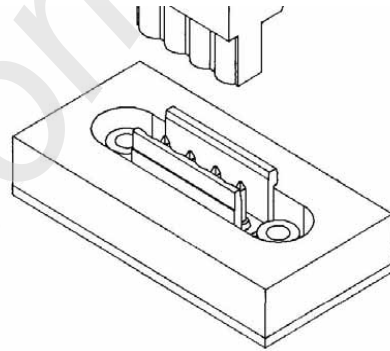

Figure 3b.

The plug is wired to the amplifier such that the connections are as follows:



Pin 1 is Positive
Pin 2 is Negative

For additional speakers, pin 3 and 4 are in parallel with pins 1 and 2, where:

Pin 3 is Negative
Pin 4 is Positive

Before connecting the speaker, ensure the wiring cover and cable clamp on the back of the can are open as shown in **Figure 3c**. Connect the wired plug into the socket.

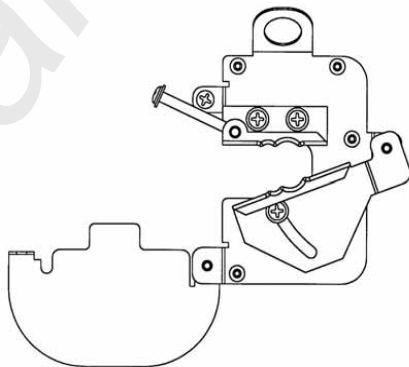

Figure 3c

When the plug has been connected, close the wiring cover as shown in **Figure 3d**, below:
Place the wires in the recess in the cable clamp. Close the cable clamp as shown in **Figure 3e** and tighten the screw holding the clamp in order to secure the cables in place.

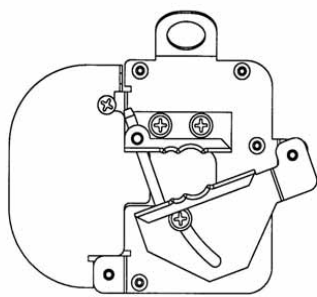

Figure 3d

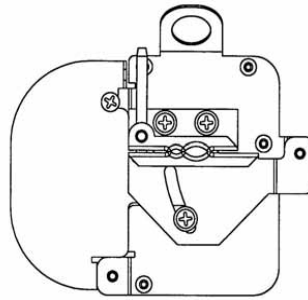

Figure 3e

3.3 Installation

The CMS60 TDC – 60 / CMS60 TDC - 8 is supplied as a complete product, ready for installation. An optional C Ring, Tile Bridge and Plaster Ring are available if required. The CMS60 TDC– 60 / CMS60 TDC - 8 has been designed for ease of installation.

To install the speaker, connect the speaker as described in the section 3.2. The speaker has 4 tags (**Figure f**), which hold the speaker in place. Ensure these tags are flat against the can before installing into the ceiling.

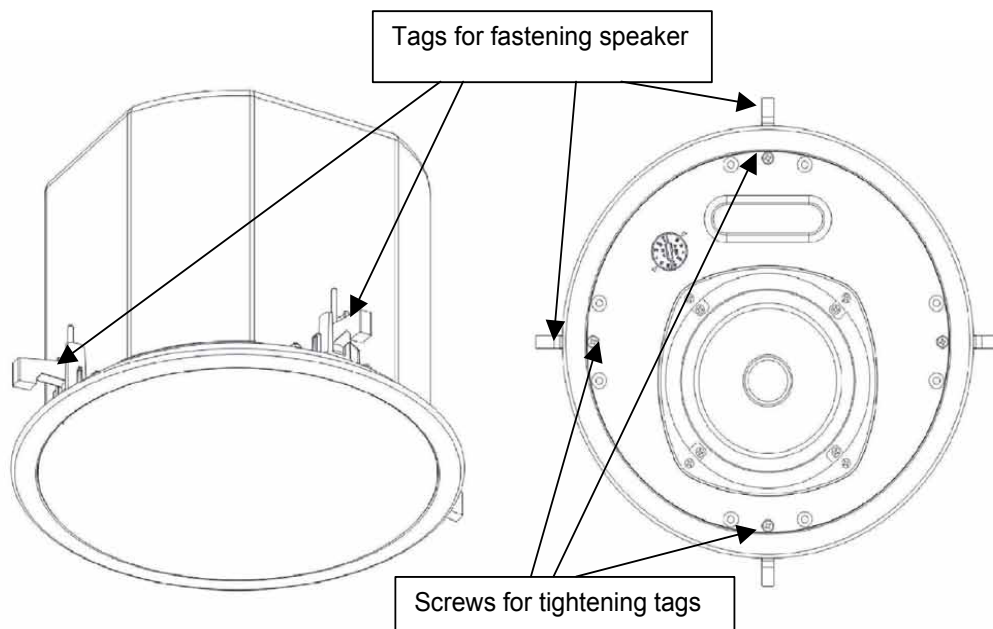

Figure f.

Slide the speaker through the 305mm hole, as shown in **figure g**, and tighten the outer screws on the front baffle. Tighten these screws until a secure grip is established as shown in **Figure h**.

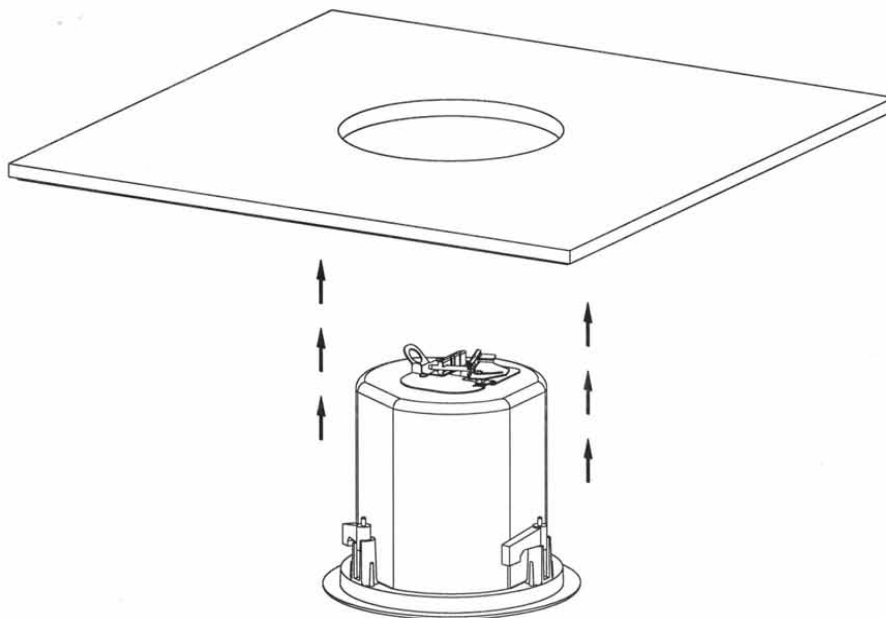

Figure g

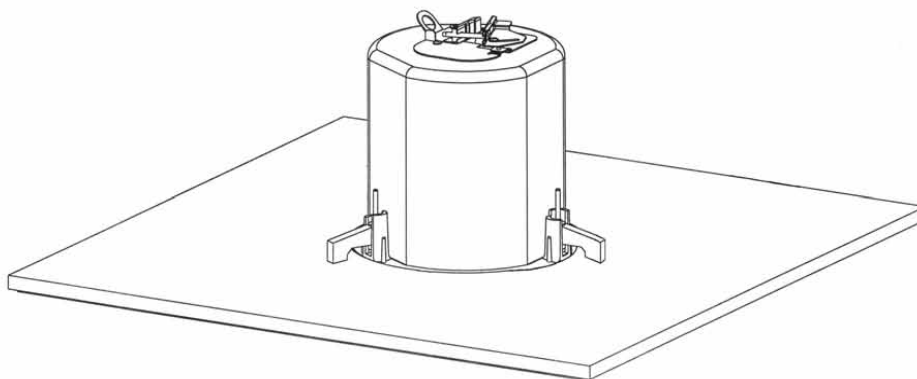
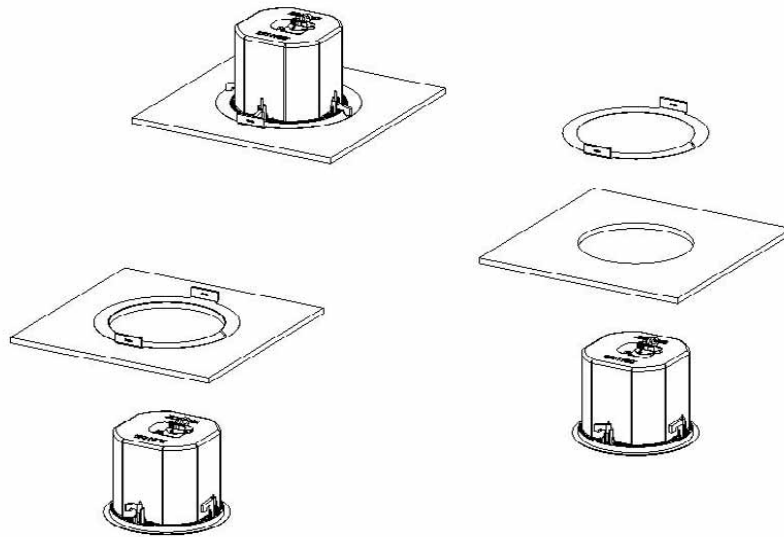

Figure h

3.4 Speaker Assembly with C-ring

To spread the weight / pressure of the 4 tags, an optional C-ring is available for the CMS60 TDC – 60 / CMS60 TDC - 8. To install the speaker in the ceiling, place the C-ring behind the surface by separating opening of the C-ring and twisting it through the hole. Slide the speaker assembly through the hole and tighten the tag screws, until a firm grip is achieved,



3.5 Speaker Assembly with Tile Bridge and C-ring

If the speaker requires additional support, an optional Tile-bridge is also available for use in conjunction with the C-Ring. This is assembled as shown in below. The Tile Bridge is attached to the C-ring, and the tile bridge supports are placed either on the supporting framework for the false ceiling or inside the framework, depending on the ceiling grid spacing. Slide the speaker assembly through the hole and tighten the tag screws, until a firm grip is achieved.

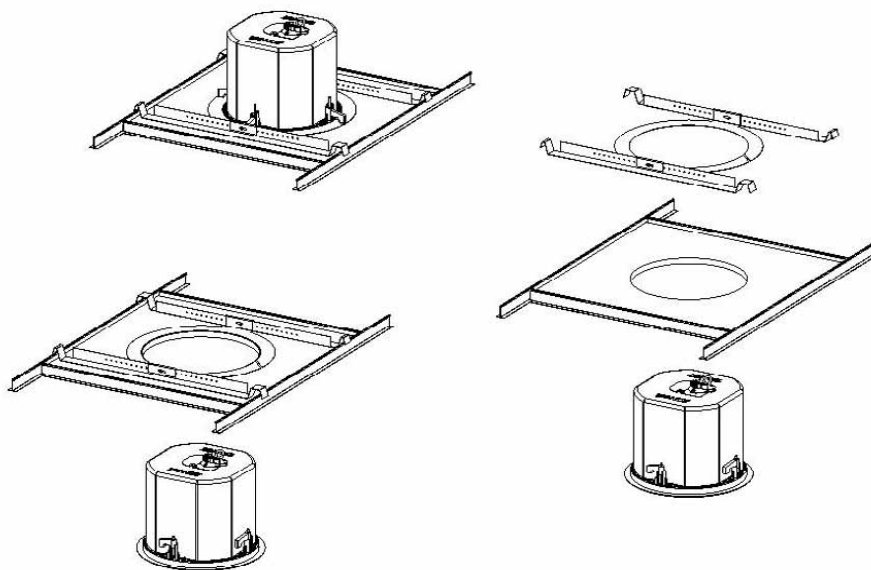

3.6 Speaker Assembly with Plaster 'Mud' Ring

An optional plaster (Mud) ring can be used if a conventional ceiling tile is not being used. The wings on the plaster ring are attached to the building structure using the holes provided. The plaster is then applied over the bracket.

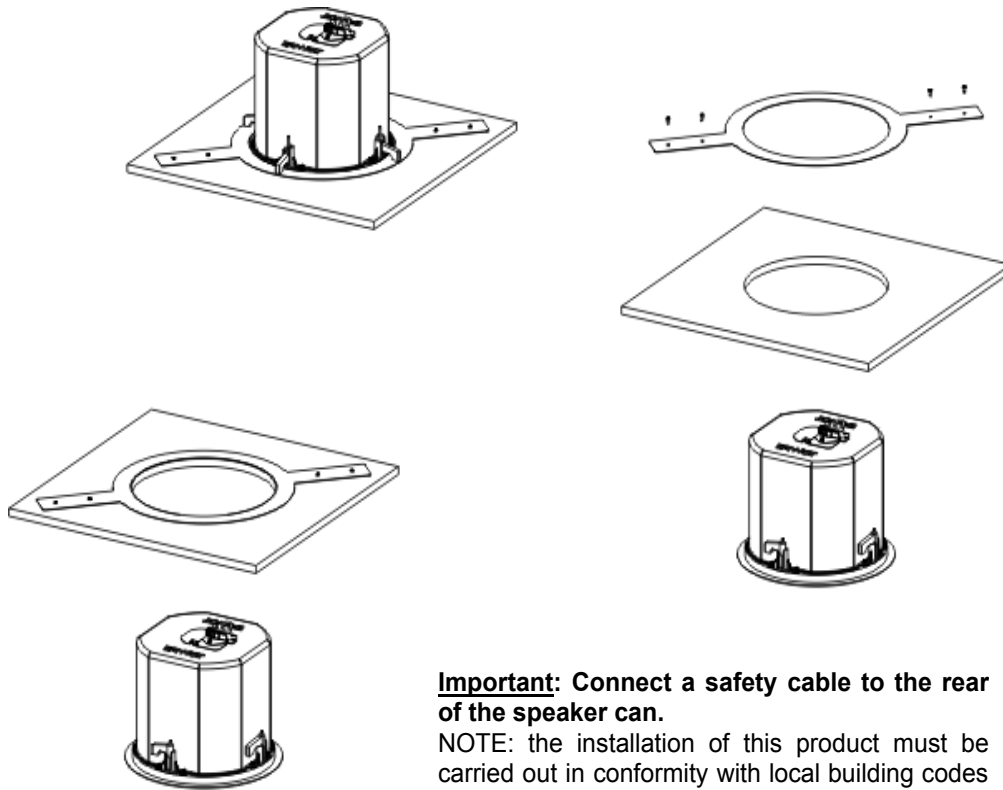

Important: Connect a safety cable to the rear of the speaker can.

NOTE: the installation of this product must be carried out in conformity with local building codes and standards. If necessary consult your local safety standards officer before installing any product. Alternatively, check any laws or bylaws. Tannoy will not be held responsible for any damages caused by the improper installation of loudspeaker.

4. Polarity Checking

It is most important to check the polarity of the wiring. A simple method of doing this without a pulse based polarity checker is as follows: Connect two wires to the +^{ve} and -^{ve} terminals of a PP3 battery. Apply the wire that is connected to the +^{ve} terminal of the battery to the speaker cable leg which you believe to be connected to the red speaker terminal, and likewise the -^{ve} leg of the battery to the black speaker terminal.

If you have wired it correctly the LF drive unit will move forward, indicating the wiring is correct. All that remains now is to connect the +^{ve} speaker lead to the +^{ve} terminal on the amplifier and the -^{ve} lead to the -^{ve} terminal on the amplifier. If, however, the LF driver moves backwards, the input connections need to be inverted.

If problems are encountered, inspect the cable wiring in the first instance. It should also be noted that different amplifier manufacturers utilise different pin configurations and polarity conventions. If you are using amplifiers from more than one manufacturer, check the polarity at the amplifiers as well as the loudspeakers.

5. Amplification and Power Selection (Low Impedance Mode)

As with all professional loudspeaker systems, the power handling is a function of voice coil thermal capacity. Care should be taken to avoid running the amplifier into clip (clipping is the end result of overdriving any amplifier). Damage to the loudspeaker will be sustained if the amplifier is driven into clip for any extended period of time. Headroom of at least 3 dB should be allowed. When evaluating an amplifier, it is important to take into account its behaviour under low impedance load conditions. A loudspeaker system is highly reactive and with transient signals it can require more current than the nominal impedance would indicate.

Generally higher power amplifier running free of distortion will do less damage to the loudspeaker than a lower power amplifier continually clipping. It is also worth remembering that a high powered amplifier running at less than 90% of output power generally sounds a lot better than a lower power amplifier running at 100%. An amplifier with insufficient drive capability will not allow the full performance of the loudspeaker to be realised.

It is important when using different manufacturers amplifiers in a single installation that they have very closely matched gains, the variation should be less than $\pm 0.5\text{dB}$. This precaution is important to the overall system balance when only a single compressor/limiter or active crossover is being used with multiple cabinets; it is therefore recommended that the same amplifiers be used throughout.

6. Voltage and Power Selection (Distributed Line Operation)

When using 70.7V or 100V distributed-line systems, the transformer can be tapped at 60W, 30W and 15W, with an extra 7.5W tapping for 70.7V line systems. The taps are selected via a rotary switch, as shown in *Figure 6a*, and is located on the front of the unit, behind the grille, *Figure 6b*.

When the relevant voltage tapings have been selected add the individual power in Watts at all speakers and select an amplifier with a rating equal to or exceeding the total power in Watts. All of the transformer primaries should be connected in parallel to the output of this amplifier. If for example, you select the 7.5-watt transformer tap, it means that at full rated amplifier output the speaker will receive the full 7.5 watts. If the amplifier gain is reduced each speaker will receive a proportional amount of power, maintaining the overall system balance.

It is recommended that a generous power safety margin (3dB of headroom) be left so that the system does not have to operate continuously at its full rated output power.

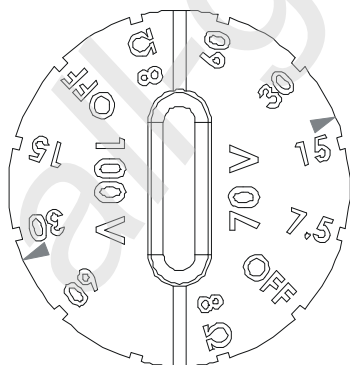

Figure 6a

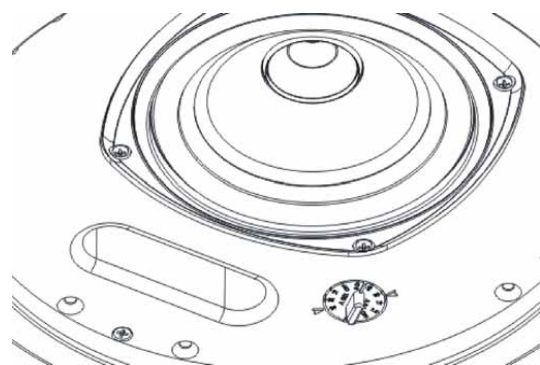

Figure 6b

In order to comply with relevant fire safety regulations (i.e. BS 5839:1998), it is required that in the event of fire, that failure of the circuit to which the loudspeaker is connected does not occur before evacuation of the building is complete. Suitable measures include:

- a) use of terminal blocks (for connection to primary) with a melting point of not less than 650°C , for example constructed from ceramic materials;
- c) use of terminal blocks of a lower melting point but protected with thermal insulation;
- d) use of terminal blocks such that, on melting, an open-circuit or a short-circuit does not occur.

7. Equalisation

The CMS60 TDC – 60 / CMS60 TDC - 8 is designed to need no equalisation or correction to overcome system limitations. As a result, it will only need equalisation to compensate for difficult acoustic environments.

Excess equalisation can reduce system headroom, and introduce phase distortion resulting in greater problems than it cures. If equalisation is required then it should be applied gently and smoothly. Violent equalisation will be detrimental to the overall sound quality. If the loudspeakers were being used consistently at high levels it would be beneficial to introduce a high-pass filter at 50Hz to protect the loudspeaker from any unnecessary subsonic frequencies.

8. Dimensions

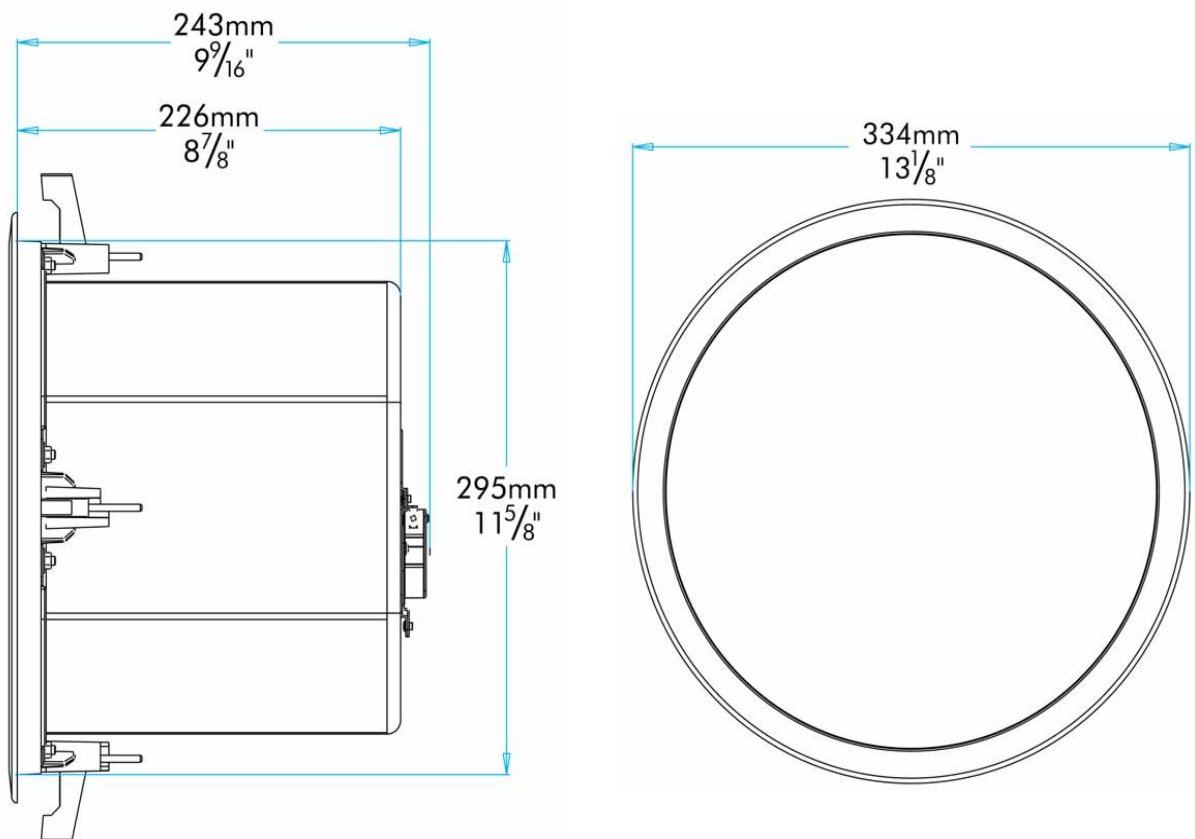

9. Performance Data

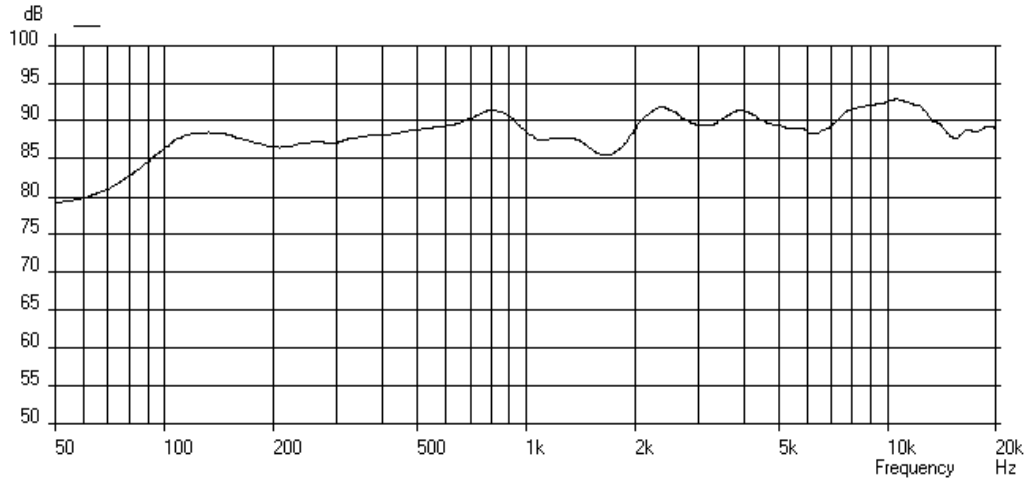

Unprocessed Anechoic Frequency Response, 1 watt @ 1 metre

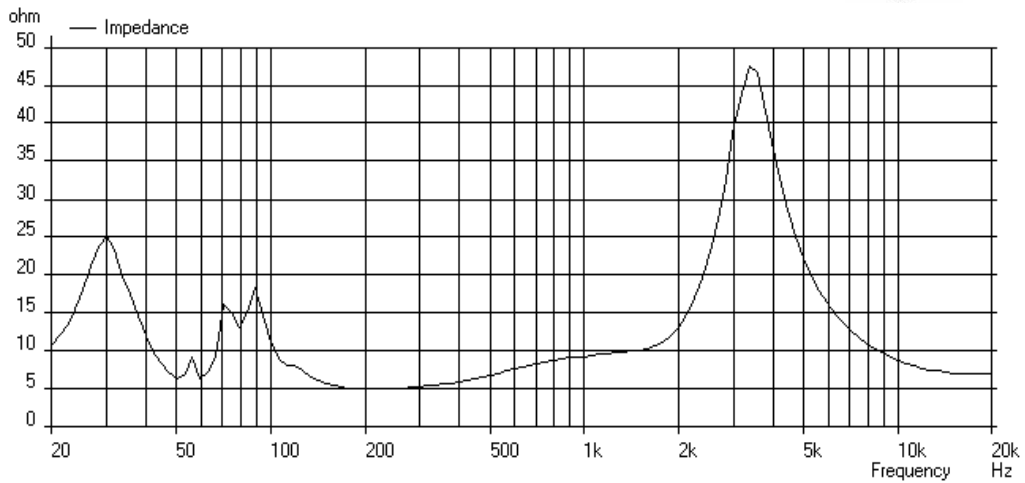

Impedance



Beamwidth vs Frequency

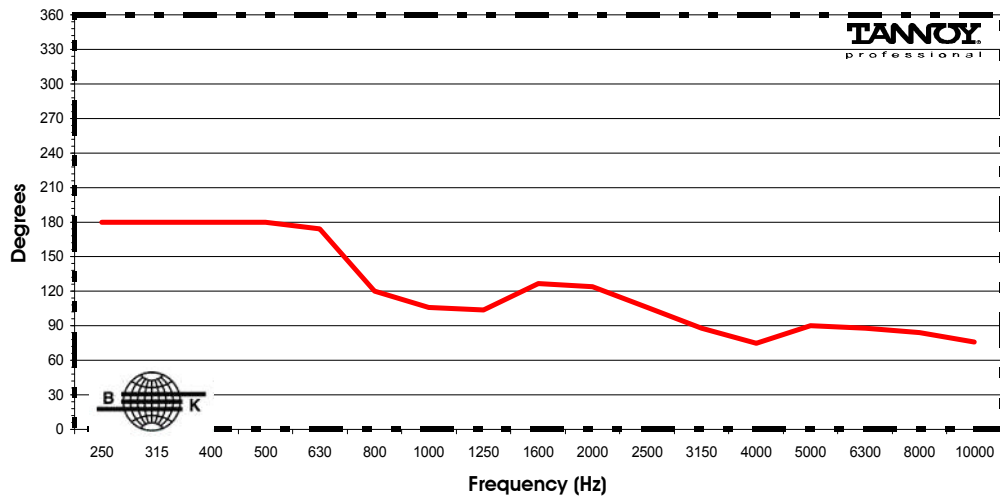

10. Technical Specifications

Frequency Response (1) +/-3 dB		50Hz - 20kHz
Sensitivity 1W @ 1m (3)		90dB (anechoic) 93dB (half space)
Maximum SPL	THP 60	108dB(average) 114dB(peak)
	Low Impedance	109dB(average) 115dB(peak)
Power Handling (2)	Average Programme	80 watt 160 watt
Impedance		Nominal: 8ohms (on low impedance setting)
Dispersion		See Beamwidth Plot
Driver Complement		6.5" (165mm) full range Dual Concentric™
Crossover		2kHz
Connectors		Removable locking connector with screw input and output terminals.
Safety Features		Rear safety tie back ring located at rear top of enclosure for attachment of a load bearing safety bond.
Enclosure		12 litres, vented with removable steel back can
Finish		White
Weight (each)		5.5kg (12.1 lbs)
Dimensions	Baffle Diameter	334mm (13 1/8")
	Can Height	226mm (8 7/8"), 243mm (9 9/16") incl. Tie back ring
	Cutout size	305mm (12")
Accessories (Optional)		C ring Tile Bridge Plaster ('mud') ring
Shipping Weight (Pair)		11.8kg (25.96 lbs)
Shipping Dimensions (Pair)		750mm x 330mm x 40mm (29.53") x (13") x (1.575")

NOTES:

- (1) Average over stated bandwidth. Measured at 1m on axis.
- (2) Long term power handling capacity as defined in EIA standard RS - 426A.
- (3) Unweighted pink noise input, measured at 1m in an anechoic chamber

A comprehensive range of measurements including off axis frequency response curves, octave & third octave polar diagrams, beamwidth plots as well as Ease™ data can be downloaded from <http://www.tannoy.com/>

Tannoy operates a policy of continuous research and development. The introduction of new materials or manufacturing methods will always equal or exceed the published specifications, which Tannoy reserves the right to alter without prior notice. Please verify the latest specifications when dealing with critical applications.

11. CMS60 TDC Recommended Service Parts & Accessories

Part Number	Description
7900 0437	Driver Kit – 6.5" Type 1667
7900 0306	Recone Kit
7900 0648	HF Diaphragm
8001 1920	CMS60 C Ring
8000 1910	CMS60 Tile Bridge
8000 1900	CMS60 Plaster Ring

12. Warranty

No maintenance of the CMS60 TDC loudspeaker is necessary.

All Tannoy professional loudspeaker products are covered by a 5 year warranty from the date of manufacture subject to the absence of misuse, overload or accidental damage. Claims will not be considered if the serial number has been altered or removed. Work under warranty should only be carried out by a Tannoy Professional dealer or service agent. This warranty in no way affects your statutory rights. For further information please contact your dealer or distributor in your country. If you cannot locate your distributor please contact Customer Services, Tannoy Ltd at the address given below.

Customer Services
Tannoy Ltd.
Rosehall Industrial Estate
Coatbridge
Strathclyde
ML5 4TF
Scotland

Telephone: 01236 420199 (National)
+44 1236 420199 (International)
Fax: 01236 428230 (National)
+44 1236 428230 (International)
e-mail: prosales@tannoy.com

DO NOT SHIP ANY PRODUCT TO TANNOY WITHOUT PREVIOUS AUTHORISATION

Our policy commits us to incorporating improvements to our products through continuous research and development. Please confirm current specifications for critical applications with your supplier.

13. Declaration of Conformity



The following apparatus is/are manufactured in the United Kingdom by Tannoy Ltd of Rosehall Industrial estate, Coatbridge, Scotland, ML5 4TF and conform(s) to the protection requirements of the European Electromagnetic Compatibility Standards and Directives relevant to Domestic Electrical Equipment. The apparatus is designed and constructed such that electromagnetic disturbances generated do not exceed levels allowing radio and telecommunications equipment and other apparatus to operate as intended, and, the apparatus has an adequate level of intrinsic immunity to electromagnetic disturbance to enable operation as specified and intended.

Details of the Apparatus:

Tannoy Contractor Loudspeaker

Associated Technical File:

Model Number: CMS60 TDC

Applicable Standards:

EMC CMS60 TDC

EN 50081-1 Emission

EN 50082-1 Immunity

EN 60065

Electrical Safety:

Signed:

A handwritten signature in black ink, appearing to read 'G. Hawley', with a horizontal line extending to the right.

Position:
Products

Engineering Director – Professional

Tannoy Professional

Date:

10/10/2002

For Tannoy Ltd

TANNOY®

**Tannoy Loudspeakers are manufactured
in Great Britain by :**

**Tannoy Ltd, Rosehall Industrial Estate, Coatbridge,
Strathclyde, ML5 4TF, SCOTLAND
Telephone: +44 (0)1236 420199 Fax: +44 (0)1236 428230**

Tannoy North America Inc, Suite 1. 335 Gage Avenue, Kitchener, Ontario, CANADA, N2M 5E1
Telephone: (519) 745 1158 Fax: (519) 745 2364

Tannoy Nederland BV, Anthonetta Kuijlstraat 19, 3066 GS, Rotterdam THE NETHERLANDS
Telephone: (010) 2860554 Fax: (010) 2860431

Issue 1.0 Part No. 6481 0392

GH 10th October 2002